

## PERFORMANCE 40 CLASS NATIONAL CHAMPIONSHIPS 5 – 6 OCTOBER 2024

ORGANISING AUTHORITY  
ROYAL YACHT SQUADRON  
COWES

# SAILING INSTRUCTIONS

*(Amended 04/10/2024 with further details concerning the "last race of the day back to the RYS" with the changes highlighted in Yellow)*

*The notation '[DP]' in a rule in the Sailing Instructions means that the penalty for a breach of that rule may, at the discretion of the protest committee, be less than disqualification.*

*The notation '[NP]' in a rule of the sailing instructions (SIs) means that a boat may not protest another boat for breaking that rule. This changes RRS 60.1(a).*

### 1. RULES

1.1 See Notice of Race (NoR) 1.

### 2. CHANGES TO SAILING INSTRUCTIONS

2.1 Any change to the Sailing Instructions (SIs) made ashore will be posted by 0900 on the day it will take effect, except that any change to the Schedule of races will be posted by 2000 on the day before it will take effect.

### 3. COMMUNICATIONS WITH COMPETITORS

3.1 Notices to competitors will be posted on the Official Notice Board (ONB). The ONB will be online at [www.rys.org.uk](http://www.rys.org.uk).

3.2 The Race Committee (RC) intends to broadcast race information and course information by VHF Channel 05 and repeated on the Event Telegram Group. See Addendum B.

3.3 On each racing day, the RC will provide a morning briefing by VHF and Telegram at 0900.

3.4 Competitors wishing to communicate with the RC should do so on VHF Channel 77.

### 4. CODE OF CONDUCT

4.1 Competitors and support persons shall comply with reasonable requests from race officials.

### 5. SIGNALS MADE ASHORE AND AFLOAT

5.1 Signals made ashore will be displayed at the RYS Flagstaff and advised on the event Telegram Group.

5.2 When Flag AP is displayed ashore, "1 minute" is replaced by "not less than 45 minutes". This changes Race Signals AP.

### 6. SCHEDULE

6.1 See NoR 9.

6.2 To alert boats that a race or sequence of races will begin soon, the Orange Starting Line Flag will be displayed with multiple sound signals not less than 5 minutes before the Warning Signal.

### 7. CLASS FLAGS

The Class Flag is shown below.

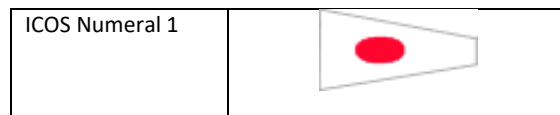

### 8. RACING AREA

8.1 Racing will take place from a Committee Vessel (CV) in the Central and Eastern Solent.

### 9. COURSES

9.1 The courses to be sailed will predominantly be a windward/leeward (W/L) configuration as described in Addendum A.

9.2 If only a single windward or leeward mark is present, boats shall leave that mark to port before proceeding to the next mark of the Course.

9.3 Soon after the Orange Starting Line Flag is displayed, and before the Warning Signal, the RC Signal Vessel will display the approximate bearing and distance to Mark 1. The Course Signal, Compass Bearing and Distance to Mark 1 will also be announced on VHF.

9.4 In cross-tide wind conditions, after the first leg, subsequent legs of the course may be 'walked' down tide to achieve reasonable leeward or windward legs.

(a) Flag W will be displayed at or before the Warning Signal for a race where the course will be 'walked' down tide.

(b) When Flag W has been displayed, no course changes (using flag C) or new marks will be used except when the leg length is being increased or decreased or the course is changed for a wind shift. This changes RRS Race Signals and RRS 33.

9.5 It is the intention of the RC to make the last race each day a "round the cans" race. Courses will be set in the Solent using the Solent Two Character Codes. See Addendum C of these SIs.

9.6 The "round the cans" courses to be sailed will be announced by the RC (call sign: Castle Two) on VHF Channel 05 before the Warning Signal and again as soon as possible after the Preparatory Signal. The course will also be sent via the event Telegram group. See Addendum B for details of the Telegram group.

### 10. MARKS

10.1 With reference to Addendum A, marks 1, 1a, 4s & 4p will be orange inflatable marks.

10.2 The starting mark and the finishing mark will be a **Blue and White** vertical striped inflatable mark.

10.3 Change marks will be black marks.

10.4 An RC vessel positioned near a mark may display a flag showing the colour of the next mark, except for the final leg to the finish line.

### 11. OBSTRUCTIONS

11.1 All yachts shall comply with [Associated British Ports Notice to Mariners No 06 of 2024](#) giving details of a Precautionary

All correspondence should be directed to:

The Royal Yacht Squadron, The Castle, Cowes, UK, PO31 7QT. Tel: 01983 292191, Email: [mail@rys.org.uk](mailto:mail@rys.org.uk)

Area and Moving Prohibited Zone (MPZ). The MPZ shall rank as an obstruction for the purposes of RRS 19 and 20.

- 11.2 Any official boat in close attendance to a craft in difficulty is an obstruction.

## 12. THE START

- 12.1 Races will be started using RRS 26 with the Warning Signal made five (5) minutes before the Starting Signal.
- 12.2 The Start Line is between a staff displaying an Orange Flag on the CV at the starboard end and the course side of the Starting Mark at the port end.
- 12.3 Boats whose warning signal has not been made shall avoid the starting area during the starting sequence for other races.
- 12.4 If any part of a boat's hull is on the course side of the Starting Line at her Starting Signal and she is identified, the RC will attempt to hail her sail number on VHF Channel 05 after Flag X has been displayed. Failure to hail her number, failure of her to hear such a hail, or the order in which boats are hailed will not be grounds for a redress for request. This changes RRS 62.1(a).
- 12.5 A boat that does not start within five (5) minutes after her starting signal will be scored Did Not Start without a hearing. This changes RRS A5.1 and A5.2.

## 13. CHANGE OF THE NEXT LEG OF THE COURSE

- 13.1 When a change of the next leg of the course has been signalled, the RC will lay a new mark (or move the finishing line) and remove the original mark as soon as practicable. When in a subsequent change a new mark is replaced, it will be replaced by an original mark.
- 13.2 The RC may announce details of any change under SI 13.1 using VHF Channel 05.
- 13.3 The position of any mark(s) may be adjusted by up to plus or minus 10 degrees relative to previous location and up to approximately 200 metres to windward or leeward without signalling Flag C, a direction signal, a length signal, a sound signal or announcement using VHF. This changes RRS 33.

## 14. THE FINISH

- 14.1 The Finishing Line for the windward leeward course is between a staff displaying a blue flag on the CV and the course side of the Finishing Mark.
- 14.2 The finishing line for "around the cans" races will be between the RYS main flagstaff and 'Alpha' a large Orange Inflatable Buoy approximately 500m north of the RYS Main Flagstaff.

## 15. PENALTY SYSTEM

- 15.1 See **NoR 14**.

## 16. TIME LIMITS

- 16.1 The Mark 1 Time Limit, Race Time Limit (see RRS 35), Finishing Window and the Target Time for W/L Courses are shown in the table below.

Mark 1 Time Limit	Race Time Limit	Finishing Window	Target Race Time
30 mins	90 mins	20 mins	50 – 60 mins

- 16.2 If no boat has passed the first mark within the Mark 1 Time Limit, or if no boat has finished within the Race Time Limit, the race will be abandoned.

- 16.3 The Finishing Window is the time for boats to finish after the first boat sails the course and finishes. Boats failing to finish within the Finishing Window, and not subsequently retiring, penalized or given redress, will be scored TLE without a hearing. A boat scored TLE shall be scored points for the finishing place two more than the points scored by the last boat that finished within the Finishing Window. This changes RRS 35, A5.1, A5.2 and A10.

- 16.4 Failure to meet the Target Race Time will not be grounds for redress. This changes RRS 62.1(a).

- 16.5 The Race Time Limit for the "Round the Cans Race" is 120 minutes.

## 17. HEARING REQUESTS

- 17.1 The Protest Limit is 90 minutes after the last boat in their division has finished the last race of the day or the RC signals no more racing today, whichever is later. This time will be posted on the ONB.
- 17.2 Hearing Forms will be available from the Race Office at the RYS.
- 17.3 Contact mobile phone numbers should be included on the Hearing Form.
- 17.4 Notices will be posted no later than 30 minutes after the protest time limit to inform competitors of the hearings in which they are parties or named as witnesses.
- 17.5 Hearings will be held in the protest room located at the RYS, beginning at the time posted.

## 18. SCORING

- 18.1 See **NoR 15**.

## 19. SAFETY REGULATIONS

- 19.1 [DP] A boat that retires from a race shall notify the Race Committee as soon as possible on VHF Channel 77 or by hailing an official regatta support boat or RIB.

## 20. REPLACEMENT OF CREW OR EQUIPMENT

- 20.1 Substitution of damaged or lost equipment, other than minor items) is not allowed unless authorised in writing by the RC. Requests for substitution shall be made to the RC at the first reasonable opportunity, which may be after the race.

## 21. EQUIPMENT AND MEASUREMENT CHECKS

- 21.1 A boat or equipment may be inspected at any time for compliance with the class rules, NoR and SIs.

## 22. SUPPLIED BOATS

- 22.1 Not used.

## 23. OFFICIAL VESSELS

- 23.1 Mark laying vessels will be RYS RIBs.
- 23.2 The CV will be a 10m blue hulled motor catamaran – Call Sign **Castle Two**.

## 24. SUPPORT PERSON VESSELS

- 24.1 See **NoR 16**.

## 25. TRASH

- 25.1 Trash may be placed aboard official or support person vessels.

## 26. BERTHING

- 26.1 See **NoR 18**.

## 27. LAUNCHING AND HAUL OUT RESTRICTIONS

- 27.1 See **NoR 19**.

**28. DIVING EQUIPMENT AND PLASTIC POOLS**

28.1 See **NoR 20.**

**29. PRIZES**

29.1 See **NoR 24.**

**30. RISK STATEMENT**

30.1 See **NoR 22.**

**31. INSURANCE**

31.1 See **NoR 23.**

\*\*\*\*\*

**ADDENDUM A – Course configuration.**

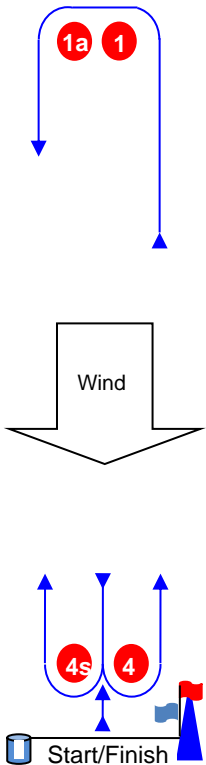
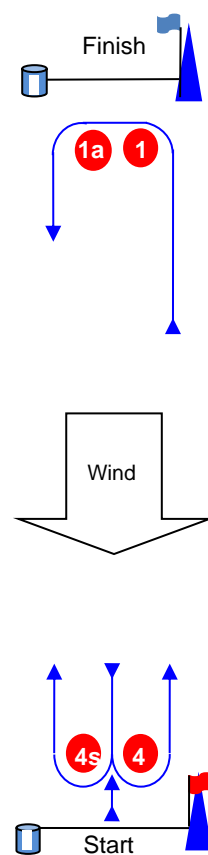
<b>Course Illustrations – Windward Leeward</b>																			
<div style="font-size: 2em; font-weight: bold; margin-bottom: 20px;">LA</div>  <p style="text-align: center; font-weight: bold; margin-top: 20px;">Course: Leeward finish</p> <table style="width: 100%; border-collapse: collapse;"> <thead> <tr> <th style="text-align: left; padding: 2px;">Signal</th> <th style="text-align: left; padding: 2px;">Mark Rounding Order</th> </tr> </thead> <tbody> <tr> <td style="padding: 2px;"><b>LA 1</b></td> <td style="padding: 2px;">Start – 1 – 1a – Finish.</td> </tr> <tr> <td style="padding: 2px;"><b>LA 2</b></td> <td style="padding: 2px;">Start – 1 – 1a – 4s/4p – 1 – 1a – Finish</td> </tr> <tr> <td style="padding: 2px;"><b>LA 3</b></td> <td style="padding: 2px;">Start – 1 – 1a – 4s/4p – 1 – 1a – 4s/4p – 1 – 1a – Finish.</td> </tr> <tr> <td style="padding: 2px;"><b>LA 4</b></td> <td style="padding: 2px;">Start – 1 – 1a – 4s/4p – 1 – 1a – 4s/4p – 1 – 1a – 4s/4p – 1 – 1a – Finish.</td> </tr> </tbody> </table>	Signal	Mark Rounding Order	<b>LA 1</b>	Start – 1 – 1a – Finish.	<b>LA 2</b>	Start – 1 – 1a – 4s/4p – 1 – 1a – Finish	<b>LA 3</b>	Start – 1 – 1a – 4s/4p – 1 – 1a – 4s/4p – 1 – 1a – Finish.	<b>LA 4</b>	Start – 1 – 1a – 4s/4p – 1 – 1a – 4s/4p – 1 – 1a – 4s/4p – 1 – 1a – Finish.	<div style="font-size: 2em; font-weight: bold; margin-bottom: 20px;">WA</div>  <p style="text-align: center; font-weight: bold; margin-top: 20px;">Course: Windward Finish</p> <table style="width: 100%; border-collapse: collapse;"> <thead> <tr> <th style="text-align: left; padding: 2px;">Signal</th> <th style="text-align: left; padding: 2px;">Mark Rounding Order</th> </tr> </thead> <tbody> <tr> <td style="padding: 2px;"><b>WA 2</b></td> <td style="padding: 2px;">Start – 1 – 1a – 4s/4p – Finish</td> </tr> <tr> <td style="padding: 2px;"><b>WA 3</b></td> <td style="padding: 2px;">Start – 1 – 1a – 4s/4p – 1 – 1a – 4s/4p – Finish.</td> </tr> <tr> <td style="padding: 2px;"><b>WA 4</b></td> <td style="padding: 2px;">Start – 1 – 1a – 4s/4p – 1 – 1a – 4s/4p – 1 – 1a – 4s/4p – Finish.</td> </tr> </tbody> </table>	Signal	Mark Rounding Order	<b>WA 2</b>	Start – 1 – 1a – 4s/4p – Finish	<b>WA 3</b>	Start – 1 – 1a – 4s/4p – 1 – 1a – 4s/4p – Finish.	<b>WA 4</b>	Start – 1 – 1a – 4s/4p – 1 – 1a – 4s/4p – 1 – 1a – 4s/4p – Finish.
Signal	Mark Rounding Order																		
<b>LA 1</b>	Start – 1 – 1a – Finish.																		
<b>LA 2</b>	Start – 1 – 1a – 4s/4p – 1 – 1a – Finish																		
<b>LA 3</b>	Start – 1 – 1a – 4s/4p – 1 – 1a – 4s/4p – 1 – 1a – Finish.																		
<b>LA 4</b>	Start – 1 – 1a – 4s/4p – 1 – 1a – 4s/4p – 1 – 1a – 4s/4p – 1 – 1a – Finish.																		
Signal	Mark Rounding Order																		
<b>WA 2</b>	Start – 1 – 1a – 4s/4p – Finish																		
<b>WA 3</b>	Start – 1 – 1a – 4s/4p – 1 – 1a – 4s/4p – Finish.																		
<b>WA 4</b>	Start – 1 – 1a – 4s/4p – 1 – 1a – 4s/4p – 1 – 1a – 4s/4p – Finish.																		

All correspondence should be directed to:

**The Royal Yacht Squadron**, The Castle, Cowes, UK, PO31 7QT. Tel: 01983 292191, Email: [mail@rys.org.uk](mailto:mail@rys.org.uk)

**ADDENDUM B – Telegram Instructions.**



**Telegram**

We have set up an official [Telegram](#) Group for receiving general information from the Race Office and Race Committee.

If you do not already have the Telegram app installed on your device, please follow the instructions below:

- **Apple iPhones** – download and install via the App Store.  
<https://apps.apple.com/app/telegram-messenger/id686449807>
- **Android Phones** – download and install via the Google Play Store.  
<https://play.google.com/store/apps/details?id=org.telegram.messenger>

To join the Telegram Group please use either the link or the QR code below:

**LINK:** <https://t.me/+QEtdHtBVj5A1ZGM8>

**QR Code:**

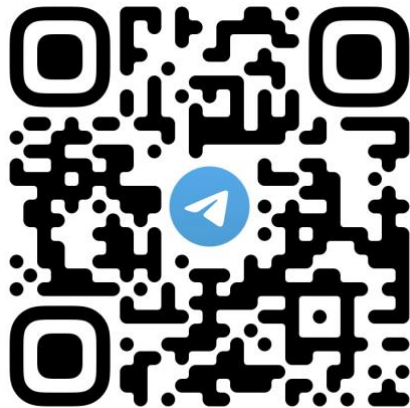

**ADDENDUM C – Solent Two Character Codes**

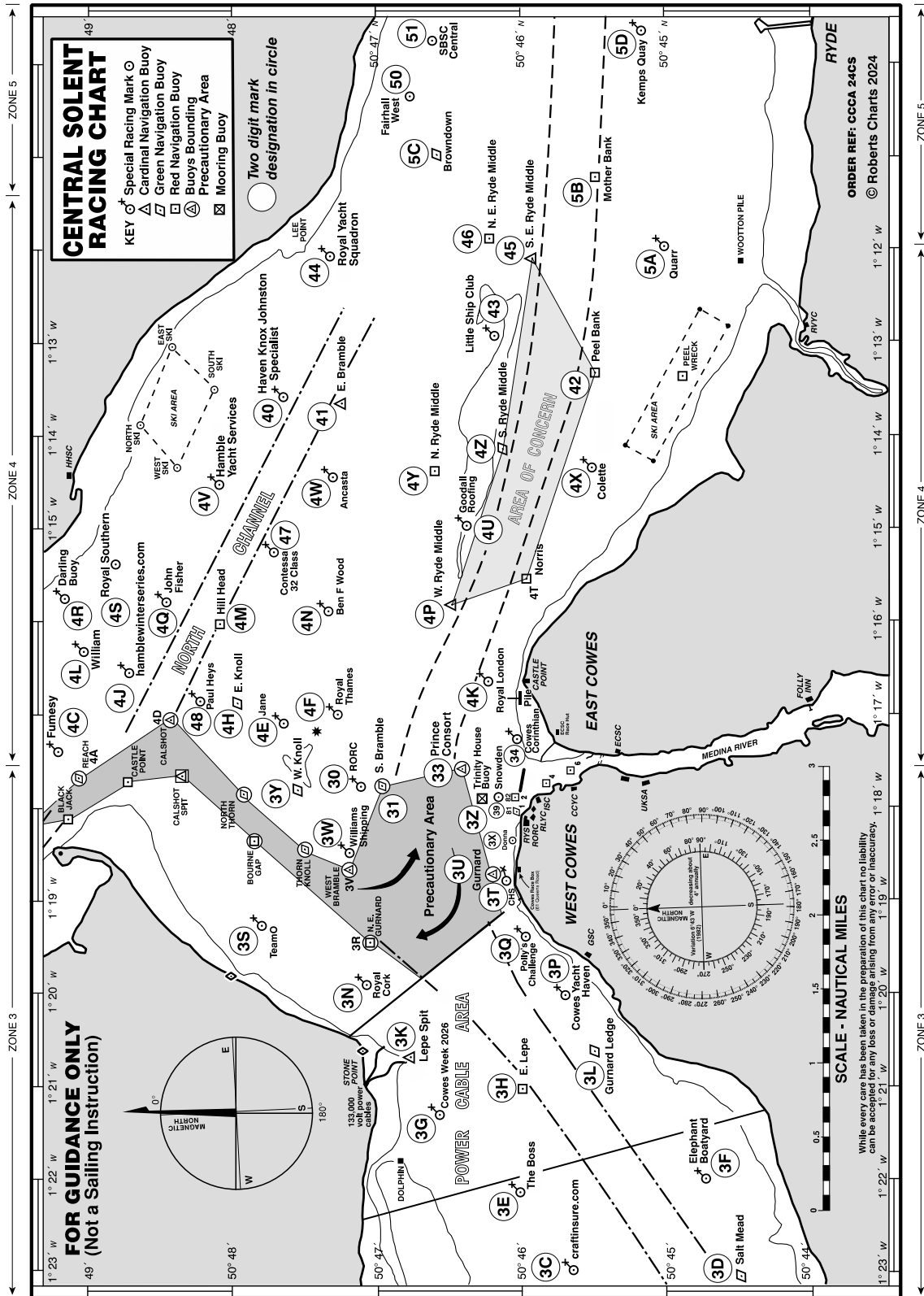

All correspondence should be directed to:

The Royal Yacht Squadron, The Castle, Cowes, UK, PO31 7QT. Tel: 01983 292191, Email: [mail@rys.org.uk](mailto:mail@rys.org.uk)

**Solent Two-Character Racing Marks 2024**

Zone 2 West Solent				
ID	Name	Colour	Lat N	Long W
2A	Embley School	Y	50 42.77	01 32.43
2B	Dunford Construction	Y	50 43.38	01 31.54
2C	Colten	Y	50 43.83	01 30.86
2D	Lymington Yacht Haven	Y	50 44.17	01 30.10
2E	Circle Marine Insurance	Y	50 44.49	01 29.32
2F	Berthon	Y	50 44.20	01 29.22
2G	Bridgeworks WAN Acceleration	Y	50 44.79	01 28.47
2H	Draycott Chartered Surveyors	Y	50 44.30	01 28.16
2J	Zwerwer	Y	50 45.11	01 27.34
2K	Greenings Fintech	Y	50 44.83	01 26.09
2L	Royal Lymington YC	Y	50 43.14	01 31.95
2R	Powder Byrne	Y	50 45.43	01 25.89
2T	Lymington Bank	R	50 43.10	01 30.85
2U	Tuakana Construction	R	50 43.67	01 29.50
2X	Solent Bank	BY	50 44.23	01 27.37
20	Sconce	G	50 42.53	01 31.43
21	Black Rock	Y	50 42.57	01 30.59
22	Charles Stanley	Y	50 42.86	01 29.40
24	Now Students	Y	50 42.86	01 28.42
26	Hamstead Ledge	G	50 43.87	01 26.18
27	Adam Harding-Domeney	Y	50 42.97	01 28.16
28	Harwoods	Y	50.42.73	01.28.69

Zone 3 Mid Solent (W)				
ID	Name	Colour	Lat N	Long W
3A	West Lepe	R	50 45.24	01 24.09
3B	MDL Marinas	Y	50 44.36	01 23.80
3C	craftinsure.com	Y	50 45.64	01 23.12
3D	Salt Mead	G	50 44.51	01 23.04
3E	The Boss	Y	50 46.13	01 22.19
3F	Elephant Boatyard	Y	50 44.72	01 21.95
3G	Cowes Week 2026	Y	50 46.58	01 21.46
3H	East Lepe	R	50 45.93	01 21.07
3K	Lepe Spit	YB	50 46.78	01 20.64
3L	Gurnard Ledge	G	50 45.51	01 20.59
3N	Royal Cork	Y	50 47.07	01 19.88
3P	Cowes Yacht Haven	Y	50 45.68	01 19.98
3Q	Polly's Challenge	Y	50 45.97	01 19.45
3R	North East Gurnard #	R	50 47.06	01 19.42
3S	TeamO	Y	50 47.81	01 19.25
3T	CHS	Y	50 46.10	01 18.87
3U	Gurnard	BY	50 46.22	01 18.84
3V	West Bramble #	YBY	50 47.20	01 18.65
3W	Williams Shipping	Y	50 47.20	01 18.55
3X	Donna	Y	50 46.10	01 18.43
3Y	West Knoll	Y	50 47.43	01 17.84
3Z	Trinity House Buoy	Y	50 46.31	01 17.75
30	RORC	Y	50 47.12	01 17.72
31	South Bramble	G	50 46.98	01 17.72
33	Prince Consort	BY	50 46.41	01 17.56
34	Cowes Corinthian	Y	50 46.15	01 17.20
39	Snowden	Y	50 46.20	01 17.75

Zone 4 Mid Solent (E)				
ID	Name	Colour	Lat N	Long W
4A	Reach #	G	50 49.05	01 17.65
4B	Coronation	Y	50 49.55	01 17.62
4C	Fumesy	Y	50 49.21	01 17.46
4D	Calshot #	BY	50 48.44	01 17.03
4E	Jane	Y	50 47.67	01 17.00
4F	Royal Thames	Y	50 47.20	01 17.00
4G	Chieftain Training	Y	50 49.45	01 16.91
4H	East Knoll	G	50 47.96	01 16.83
4J	hamblewinterseries.com	Y	50 48.63	01 16.56
4K	Royal London	Y	50 46.15	01 16.65
4L	William	Y	50 49.03	01 16.49

Zone 4 Mid Solent (E continued)				
ID	Name	Colour	Lat N	Long W
4M	Hill Head	R	50 48.07	01 16.00
4N	Ben F Wood	Y	50 47.27	01 15.90
4P	West Ryde Middle	YBY	50 46.48	01 15.79
4Q	John Fisher	Y	50 48.46	01 15.72
4R	Darling Buoy	Y	50 49.18	01 15.71
4S	Royal Southern	Y	50 48.86	01 15.43
4T	Norris #	R	50 45.97	01 15.51
4U	Goodall Roofing	Y	50 46.43	01 15.09
4V	Hamble Yacht Services	Y	50 48.13	01 14.64
4W	Ancasta	Y	50 47.33	01 14.59
4X	Colette	Y	50 45.53	01 14.39
4Y	North Ryde Middle	R	50 46.61	01 14.31
4Z	South Ryde Middle	G	50 46.13	01 14.16
40	Haven Knox Johnston Specialist	Y	50 47.66	01 13.65
41	East Bramble	BYB	50 47.23	01 13.64
42	Peel Bank	R	50 45.49	01 13.35
43	Little Ship Club	Y	50 46.16	01 13.09
44	Royal Yacht Squadron	Y	50 47.31	01 12.10
45	South East Ryde Middle	YB	50 45.93	01 12.10
46	North East Ryde Middle	R	50 46.21	01 11.88
47	Contessa 32 Class	Y	50 47.70	01 15.25
48	Paul Heys	Y	50 48.21	01 16.68

Zone 5 East Solent				
ID	Name	Colour	Lat N	Long W
5A	Quarr	Y	50 45.03	01 11.89
5B	Mother Bank	R	50 45.49	01 11.21
5C	Browndown	G	50 46.57	01 10.95
5D	Kemp's Quay	Y	50 45.18	01 09.65
5E	Stokes Bay East	Y	50 46.26	01 08.76
5F	North Sturbridge	BY	50 45.33	01 08.23
5G	Baker Trayte Marine	Y	50 46.42	01 07.90
5H	Potsmouth SC	Y	50 46.82	01 07.35
5J	KB Dry Stack	Y	50 46.61	01 07.29
5K	Suffolk Sails	Y	50 47.08	01 06.78
5M	Gleeds	Y	50 46.11	01 06.52
5N	Mary Rose	Y	50 45.80	01 06.20
5P	Linington	Y	50 46.36	01 06.08

Zone 6 Eastern Approaches				
ID	Name	Colour	Lat N	Long W
6A	No Man's Land Fort	B	50.44.40	01.05.70
6C	Warner	R	50.43.87	01.03.99
6E	West Princessa	YBY	50.40.16	01.03.65
6F	Bembridge Ledge Buoy	BYB	50.41.15	01.02.81
6L	Winner	YB	50.45.10	01.00.10
6M	Nab End	R	50.42.63	00.59.49
6R	Nab Tower	B	50.40.08	00.57.15

Zone 8 Local Fixed Marks				
ID	Name	Colour	Lat N	Long W
81	No 1 Cowes Harbour #	G	50.46.07	01.18.04
82	No 2 Cowes Harbour #	R	50.46.07	01.17.70

Zone 9 Laid Marks				
ID	Name	Colour	Lat N	Long W
9A	Windward Laid Mark			
9B	Windward Spreader Mark			
9C	Leeward Laid Mark			
9D	Leeward Spreader Mark			
9E	Leeward Gate			
9F	Middle Gate			
9G	Wing Mark			
9H	Outer Distance Mark			
9J	Finish Mark			
9K	Far Windward Mark			
9L	Far Windward Spreader			
9M	Near Windward Mark			
9N	Near Windward Spreader			
9I	RYS Laid Outer Distance Mark			

# *May only be used as passing marks . Not for rounding.*

© CCCA 2024

All correspondence should be directed to:

The Royal Yacht Squadron, The Castle, Cowes, UK, PO31 7QT. Tel: 01983 292191, Email: [mail@rys.org.uk](mailto:mail@rys.org.uk)