



**ELLEN MACARTHUR CANCER TRUST  
BRIGHTER FUTURES REGATTA  
21 MAY 2025**

**ORGANISING AUTHORITY  
ROYAL YACHT SQUADRON  
COWES**

## SAILING INSTRUCTIONS

### 1. RULES

- 1.1 See Notice of Race 1.

### 2. CHANGES TO SAILING INSTRUCTIONS

- 2.1 Any change to the Sailing Instructions (SIs) made ashore will be posted by 0900 on the day it will take effect.

### 3. COMMUNICATIONS WITH COMPETITORS

- 3.1 Notices to competitors will be posted on the Official Notice Board (ONB). The ONB will be online at [www.rys.org.uk](http://www.rys.org.uk)
- 3.2 The Race Committee (RC) intends to broadcast race information and course information by VHF Ch 77.
- 3.3 Competitors wishing to communicate with the RC should do so on VHF Ch 77.

### 4. CODE OF CONDUCT

- 4.1 Competitors and support persons shall comply with reasonable requests from race officials.

### 5. SIGNALS MADE ASHORE AND AFLOAT

- 5.1 Signals made ashore will be displayed at the RYS Flagstaff.
- 5.2 When Flag AP is displayed ashore, "1 minute" is replaced by "not less than 45 minutes". This changes Race Signals AP.

### 6. SCHEDULE

- 6.1 See Notice of Race 9.
- 6.2 To alert boats that a race or sequence of races will begin soon, the Orange Starting Line Flag will be displayed with multiple sound signals at least 5 minutes before the First Warning Signal of the day.

### 7. CLASS FLAGS

The Class Flag is shown below.

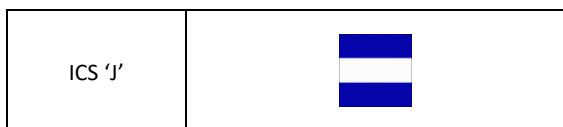

### 8. RACING AREA

- 8.1 Racing will take place from a Committee Vessel (CV), Castle 2) in the Central and Eastern Solent.

### 9. COURSES

- 9.1 The courses to be sailed will be a windward / leeward configuration as described in Addendum A. The passage race to return to the RYS, if held, may include special racing marks or navigation marks. The course will be announced on VHF Ch 77 shortly before the warning signal for that race.
- 9.2 If only a single windward or leeward mark is present, boats shall leave that mark to port before proceeding to the next mark of the Course.
- 9.3 Soon after the Orange Starting Line Flag is displayed, and before the Warning Signal, the RC Signal Vessel will display the approximate bearing and distance to Mark 1. The Course Signal, Compass Bearing and Distance to Mark 1 may also be announced on VHF.

### 10. MARKS

- 10.1 With reference to Addendum A, marks 1, 1a, 4s & 4p will be orange inflatable marks.
- 10.2 The starting mark and the finishing mark will be a blue inflatable mark.
- 10.3 Change marks will be black marks.

### 11. OBSTRUCTIONS

- 11.1 All yachts shall comply with [Associated British Ports Notice to Mariners No 06 of 2025](#) giving details of a Precautionary Area and Moving Prohibited Zone (MPZ). The MPZ shall rank as an obstruction for the purposes of RRS 19 and 20.
- 11.2 Any official boat in close attendance to a craft in difficulty is an obstruction.

### 12. THE START

- 12.1 Races will be started using RRS 26 with the Warning Signal made 5 minutes before the Starting Signal.
- 12.2 The Start Line is between a staff displaying an Orange Flag on the CV at the starboard end and the course side of the Starting Mark at the port end.
- 12.3 A boat that does not start within five (5) minutes after her starting signal will be scored Did Not Start without a hearing. This changes RRS A5.1 and A5.2.

### 13. CHANGE OF THE NEXT LEG OF THE COURSE

- 13.1 When a change of the next leg of the course has been signalled, the RC will lay a new mark (or move the finishing line) and remove the original mark as soon as practicable. When in a subsequent change a new mark is replaced, it will be replaced by an original mark.
- 13.2 The RC may announce details of any change under SI 13.1 using VHF Ch77.
- 13.3 The position of any mark(s) may be adjusted by up to plus or minus 10 degrees relative to previous location and up to approximately 200 metres to windward or leeward without signalling Flag C, a direction signal, a length signal, a sound signal or announcement using VHF. This changes RRS 33.

### 14. THE FINISH

- 14.1 The Finishing Line is between a staff displaying a blue flag on the CV and the course side of the Finishing Mark.
- 14.2 The finish line for the passage race will be a line between the RYS Main Mast and an orange inflatable mark laid approximately 200 metres off the Castle.

**15. PENALTY SYSTEM**

15.1 See Notice of Race 14.

**16. TIME LIMITS**

16.1 The target time for each race is 20-25 minutes. Failure to meet this time will not be grounds for redress. This changes RRS62.1(a).

**17. HEARING REQUESTS**

17.1 Due to the Corinthian nature of the regatta, any hearings will be resolved by arbitration managed by the RC. The RC decision will be final and not subject to redress.

**18. SCORING**

18.1 See Notice of Race 15.

**19. SAFETY REGULATIONS**

19.1 [DP] A boat that retires from a race shall notify the Race Committee as soon as possible on VHF Ch 77 or by hailing an official regatta support boat or RIB.

**20. REPLACEMENT OF CREW OR EQUIPMENT**

20.1 Substitution of competitors is permitted.

20.2 Substitution of damaged or lost equipment is permitted as managed by the RC.

**21. EQUIPMENT AND MEASUREMENT CHECKS**

21.1 Not used.

**22. SUPPLIED BOATS**

22.1 Boats will be supplied by the OA.

**23. OFFICIAL VESSELS**

23.1 Mark laying vessels will be RYS RIBs.

23.2 The CV will be a 10m blue hulled motor catamaran – Call Sign Castle Two.

**24. SUPPORT PERSON VESSELS**

24.1 See Notice of Race 16.

**25. TRASH**

25.1 Trash may be placed aboard official or support person vessels.

**26. BERTHING**

26.1 See Notice of Race 18.

**27. LAUNCHING AND HAUL OUT RESTRICTIONS**

27.1 See Notice of Race 19.

**28. DIVING EQUIPMENT AND PLASTIC POOLS**

28.1 See Notice of Race 20.

**29. PRIZES**

29.1 See Notice of Race 24.

**30. RISK STATEMENT**

30.1 See Notice of Race 22.

**31. INSURANCE**

31.1 See Notice of Race 23.

All correspondence should be directed to:

The Royal Yacht Squadron, The Castle, Cowes, UK, PO31 7QT. Tel: 01983 292191, Email: [mail@rys.org.uk](mailto:mail@rys.org.uk)

**ADDENDUM A – Course configuration.**

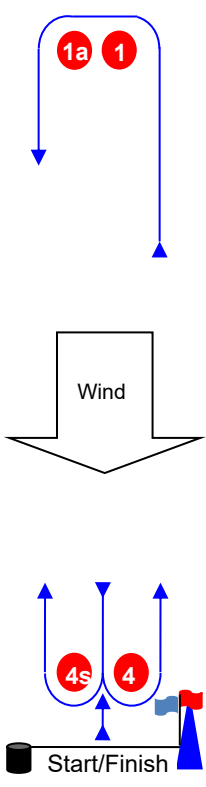
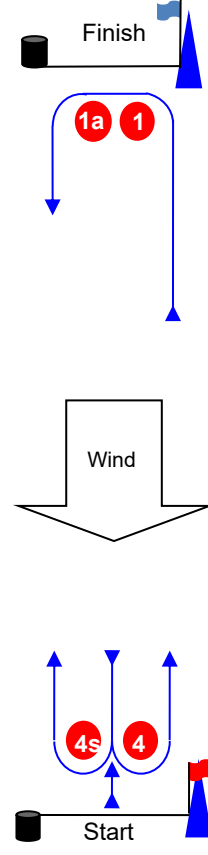
<b>Course Illustrations – Windward Leeward</b>																			
<div style="font-size: 2em; font-weight: bold; margin-bottom: 20px;">LA</div>  <p style="text-align: center; font-weight: bold; margin-top: 20px;">Course: Leeward finish</p> <table style="width: 100%; border-collapse: collapse;"> <thead> <tr> <th style="text-align: left; padding: 2px;">Signal</th> <th style="text-align: left; padding: 2px;">Mark Rounding Order</th> </tr> </thead> <tbody> <tr> <td style="padding: 2px;"><b>LA 1</b></td> <td style="padding: 2px;">Start – 1 – 1a – Finish.</td> </tr> <tr> <td style="padding: 2px;"><b>LA 2</b></td> <td style="padding: 2px;">Start – 1 – 1a – 4s/4p – 1 – 1a – Finish</td> </tr> <tr> <td style="padding: 2px;"><b>LA 3</b></td> <td style="padding: 2px;">Start – 1 – 1a – 4s/4p – 1 – 1a – 4s/4p – 1 – 1a – Finish.</td> </tr> <tr> <td style="padding: 2px;"><b>LA 4</b></td> <td style="padding: 2px;">Start – 1 – 1a – 4s/4p – 1 – 1a – 4s/4p – 1 – 1a – 4s/4p – 1 – 1a – Finish.</td> </tr> </tbody> </table>	Signal	Mark Rounding Order	<b>LA 1</b>	Start – 1 – 1a – Finish.	<b>LA 2</b>	Start – 1 – 1a – 4s/4p – 1 – 1a – Finish	<b>LA 3</b>	Start – 1 – 1a – 4s/4p – 1 – 1a – 4s/4p – 1 – 1a – Finish.	<b>LA 4</b>	Start – 1 – 1a – 4s/4p – 1 – 1a – 4s/4p – 1 – 1a – 4s/4p – 1 – 1a – Finish.	<div style="font-size: 2em; font-weight: bold; margin-bottom: 20px;">WA</div>  <p style="text-align: center; font-weight: bold; margin-top: 20px;">Course: Windward Finish</p> <table style="width: 100%; border-collapse: collapse;"> <thead> <tr> <th style="text-align: left; padding: 2px;">Signal</th> <th style="text-align: left; padding: 2px;">Mark Rounding Order</th> </tr> </thead> <tbody> <tr> <td style="padding: 2px;"><b>WA 2</b></td> <td style="padding: 2px;">Start – 1 – 1a – 4s/4p – Finish</td> </tr> <tr> <td style="padding: 2px;"><b>WA 3</b></td> <td style="padding: 2px;">Start – 1 – 1a – 4s/4p – 1 – 1a – 4s/4p – Finish.</td> </tr> <tr> <td style="padding: 2px;"><b>WA 4</b></td> <td style="padding: 2px;">Start – 1 – 1a – 4s/4p – 1 – 1a – 4s/4p – 1 – 1a – 4s/4p – 1 – 1a – 4s/4p – Finish.</td> </tr> </tbody> </table>	Signal	Mark Rounding Order	<b>WA 2</b>	Start – 1 – 1a – 4s/4p – Finish	<b>WA 3</b>	Start – 1 – 1a – 4s/4p – 1 – 1a – 4s/4p – Finish.	<b>WA 4</b>	Start – 1 – 1a – 4s/4p – 1 – 1a – 4s/4p – 1 – 1a – 4s/4p – 1 – 1a – 4s/4p – Finish.
Signal	Mark Rounding Order																		
<b>LA 1</b>	Start – 1 – 1a – Finish.																		
<b>LA 2</b>	Start – 1 – 1a – 4s/4p – 1 – 1a – Finish																		
<b>LA 3</b>	Start – 1 – 1a – 4s/4p – 1 – 1a – 4s/4p – 1 – 1a – Finish.																		
<b>LA 4</b>	Start – 1 – 1a – 4s/4p – 1 – 1a – 4s/4p – 1 – 1a – 4s/4p – 1 – 1a – Finish.																		
Signal	Mark Rounding Order																		
<b>WA 2</b>	Start – 1 – 1a – 4s/4p – Finish																		
<b>WA 3</b>	Start – 1 – 1a – 4s/4p – 1 – 1a – 4s/4p – Finish.																		
<b>WA 4</b>	Start – 1 – 1a – 4s/4p – 1 – 1a – 4s/4p – 1 – 1a – 4s/4p – 1 – 1a – 4s/4p – Finish.																		

All correspondence should be directed to:

**The Royal Yacht Squadron**, The Castle, Cowes, UK, PO31 7QT. Tel: 01983 292191, Email: [mail@rys.org.uk](mailto:mail@rys.org.uk)